

Reference Information:

OEM PN: ZT-30TD1
OEM Yield: 2,000 (5% coverage)

Printer Compatibility Information:

Xerox 5220
Sharp Z-30

Recommended Tools:

Phillips head screwdriver
Flat head screwdriver

Approximate Remanufacturing

Time: 20 min.

Instructions:

1. Remove right end cap (2 screws - Fig. 1).
2. If both the toner and developer is being replaced, go to step 3.
 - b.) If only the toner is being replaced then perform the following: **Note:** Do not vacuum toner hopper as developer may get removed.
 - a. Remove the larger hopper plug.
 - b. Refill the toner hopper with toner. Replace toner hopper plug.
 - c. Replace end cap (two screws).
3. Remove the gear off the end of the mag roller shaft (Fig. 2). Remove the two screws in the end cap. **Note:** Do not remove the screws securing the electrical connector. To split the cartridge in half, carefully remove the top portion by pulling it up and to the right.
4. Remove all old developer **Note:** Be careful not to scratch the development (magnetic/developer) roller.
5. Remove all old toner in toner section.
6. Remove the large (toner) and small (developer) plugs (Fig. 3).
7. Join the toner and developer section by guiding the locator pins on the left end into their respective holes. Replace the two screws and mag roller shaft gear.
8. Refill the developer section (small plug) with 125g. of developer. Refill the toner section (large plug) with 90 g. toner. Replace small and large plug.
9. Replace right end cap (2 screws).

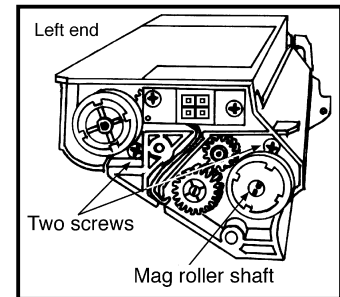

Figure 1

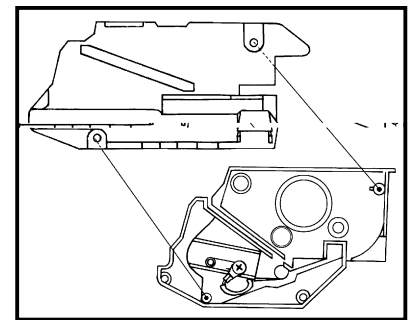

Figure 2

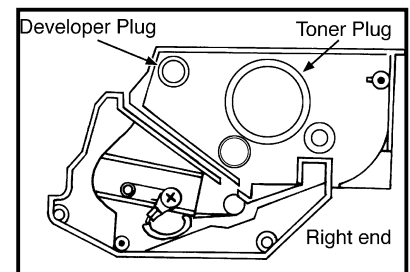

Figure 3